

89

## Hand Dryer

Air Fury C1 High Speed Hand Dryer. The Air Fury features include 10-12 seconds drying time, a blue LED for hand drying range, exceptionally long brush life for ease of maintenance and variable air speed and heating element.



Codes	Voltage	Frequency	Amps	Output Air Temperature
89	220-240V	50Hz	8A	55°C (131°F)
89-120	110-120V	60Hz	12A	50°C (108°F)

### Technical Data

Finishes	C (Chrome) / CS (Satin) / W (White)
Consumption:	1600W
Drying time	10 - 12 seconds
Weight:	5.32Kg (11lb 11oz)
Stainless steel (C & CS)	304 grade
Noise level	77dB at 1m (39")
Air speed	75-100m/s (246-328ft/s)
Heating element	900W
Motor type	Brush
Motor speed	12000 - 18000 rpm (adjustable)
Air flow	125.5 m <sup>3</sup> /h (411 ft <sup>3</sup> 8 <sup>15</sup> / <sub>16</sub> "/h)
Sensor range	51mm (2") - 330mm (13") - adjustable. Preset at 180mm (7")
Approvals / insulation:	Class 1 earthed, TUGGS approved, ROHS complaint, CE marked in accordance with EEC harmonised documents IPX1 rated.
Warranty	5 years parts, 1 year labour (from date of purchase). This excludes brushes as they are a wearing part and dependant on usage.

## Installation Guidelines

---

Fixing height	1000mm (39 $\frac{3}{8}$ " ) from floor
Washroom layout	Number of hand dryers to be fitted – in toilet areas with normal frequency one dryer for two washbasins. In high frequency toilet areas two dryers per three washbasins. In very high frequency washrooms one dryer per one washbasin. Mounting template included with dryer.
	Ideal location – between washbasins and exit. If mounted over a washbasin recommended minimum distance from dryer to basin
should be 400mm (15 $\frac{3}{4}$ " ).	Recommended substrate is a solid wall. If installed on a stud/plasterboard wall, sound levels are likely to exceed 78dB.

## Compliance

---

TUGGS

RoHS

CE

UL

ECA (enhanced capital allowance)

Eligible for capital purchase tax incentives  
(<https://etl.decc.gov.uk/etl/site.html>)

## Related Documents

---

Installation manual	email: <a href="mailto:sales@onvouk.com">sales@onvouk.com</a>
Operation and maintenance manual	email: <a href="mailto:sales@onvouk.com">sales@onvouk.com</a>
Warranty document	email: <a href="mailto:sales@onvouk.com">sales@onvouk.com</a>

### Side

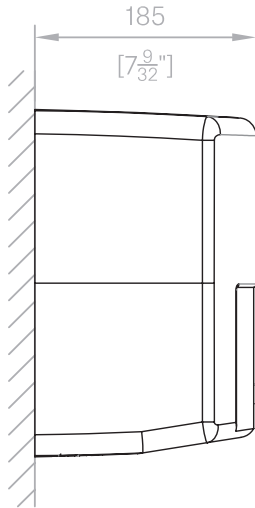

### Front

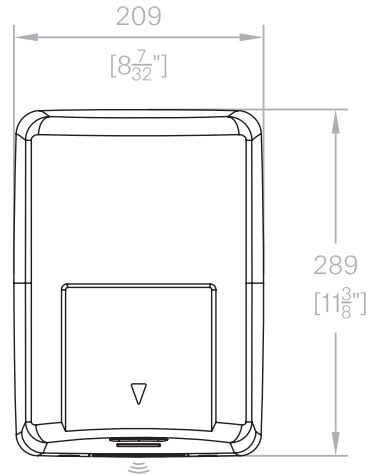

### Fixing Locations

